

HORIZONTAL ARM TIRE CHANGER

103826A/103826

INSTRUCTION MANUAL

Honest to customers

Quality & Renovation

WARNING

This instruction manual is the important part of the product. Please read it carefully and keep it properly.

Use

This machine is only applied to mount, demount and inflate the tire in the specified scope and not for any other purpose.

The manufacturer will not be responsible for the damage or injury caused for the operation not properly and out of the range.

NOTE

This machine should be operated by the special trained qualified personnel. When operating, the unauthorized personnel will be kept far away from the machine.

Please note the safety label stuck on the machine.

Operators should wear safety protective facilities such as working suit, protective glasses, eye plug and safety shoes. Keep your hands and body from the movable parts as possible as you can. Necklace, bracelet and loosen clothing may cause dangerous to the operators.

Tire changer should be installed and fixed on the flat and solid floor. The more than 0.5m of distance from the rear and lateral side of the machine to the wall can guarantee the perfect air flow and enough operation space.

Do not place the machine in the site of high temperature, high humidity, dust and with flammable and corrosion gas.

Without the permission from the manufacturer, any change on the machine parts will cause injury/damage to the machine/operator.

Pay attention that the tire changer should be operated under the specified voltage and air pressure.

If you want to move the tire changer, you should under the guidance of the professional service personnel.

SAFTTY LABEL INSTRUCTION



Keep your hands far from tire when operation

Carefully read operation manual before operation

When operation , wear the protective facilities



electrical shock !



Do not reach any part of your body under the demount tool.



When breaking bead, the bead Breaking blade will quickly move leftwards.



Note: when press the tire, the opened clamp cylinder may injury the hand of the operator. Remember, do not touch the side wall of the tire.



When clamping the rim, do not Reach your hand or other parts Of the body in between the clamp & the rim.



Do not stand behind the column to Avoid the column from injuring the persons when swing.



When rapid inflation, ensure the wheel clamped.

When operation, do not wear long hair, loosen clothing and jewelries..

When operation, do not reach y our hand under the falling objects.

SAFETY LABEL POSITION DIAGRAM

Pay attention to keep the safety labels complete. When it is not clear of missing, you should change the new label.

You should let the operators see the safety labels clearly and understand the meaning of the label.

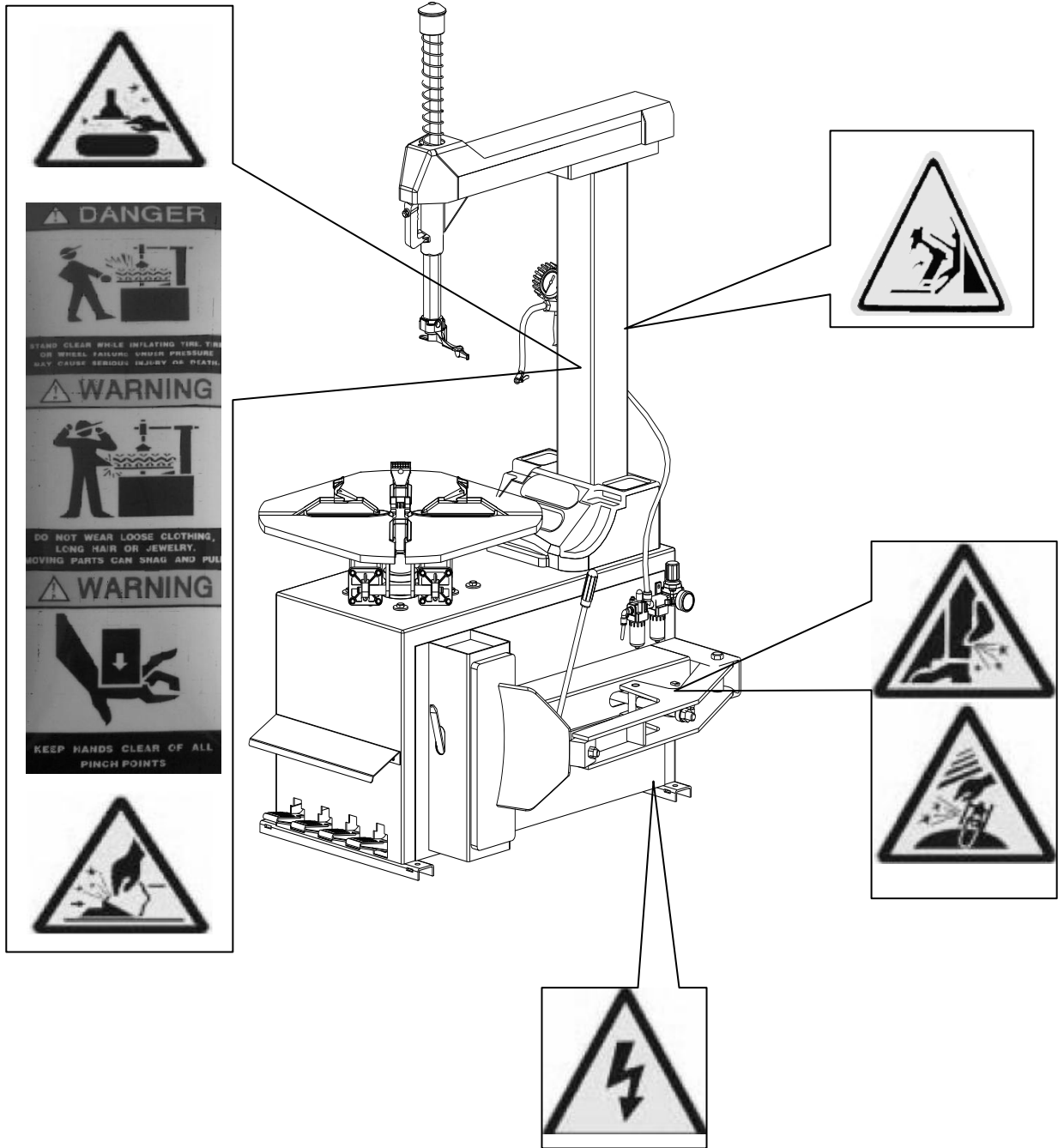

CONTENT

CHAPTER I BRIEF INTRODUCTION

1.1 BRIEF INTRODUCTION

1.2 EQUIPMENT OVERALL DIMENSION (EXCLUDING THE ASSISTANT)

1.3 TECHNICAL PARAMETER

1.4 APPLICATION SCOPE

1.5 ENVIRONMENT REQUIREMENT

CHAPTER II CONFIGURATION AND OPERATION

CHAPTER III INSTALLATION AND CALIBRATION

3.1 OPEN PACKAGE CARTON

3.2 INSTALLATION OF THE COLUMN

3.3 AIR SOURCE INSTALLATION

CHAPTER IV DEMOUNT AND MOUNT TIRE

4.1 DEMOUNT TIRE

4.2 MOUNT TIRE

4.3 INFLATION

CHAPTER V MAINTENANCE AND REPAIR

CHAPTER VI INSTALLATION & OPERATION OF THE ASSISTANT ARM

CHAPTER VII TRANSPORTATION

CHAPTER VIII ELECTRICAL AND PNEUMATIC DRAWING

CHAPTER IX GENERAL TROUBLESHOOTING AND SOLUTION

CHAPTER I BRIEF INTRODUCTION

1.1 BRIEF INTRODUCTION

103826 tire changer is the one featured with tilt and horizontal arm, suitable to mount, demount and inflate all types of car tire with tube and tubeless. The operation is easy, convenient and safety. It is the necessary equipment for the auto service shop and tire shop.

This series includes two basic models:

103826 – common type

103826A – with rapid inflation

These 2 models can be both optional equipped with left assistant PL330 and right assistant AL320 suitable to mount and demount the low profile and stiff tire.

1.2 EQUIPMENT OVERALL DIMENSION (EXCLUDING THE ASSISTANT)

model	height (mm)	length (mm)	width (mm)	Net weight kg
103826A	1910	1310	900	243
103826	1910	1050	900	218

1.3 TECHNICAL PARAMETER

Operation pressure: 8-10bar

motor: 50Hz 380V 0.75Kw(standard) 50Hz 220V 50Hz/60Hz 220V/110V 1.1Kw(optional)

turntable speed: 6rpm

noise: <70dB (A)

1.4 APPLICATION SCOPE

model	Max. wheel diameter	Max. wheel width	rim diameter (outer clamp)	rim diameter (inner clamp)
103826	1040mm(41")	400mm(16")	10"~20"	12"~23"
103826A	1040mm(41")	400mm(16")	10"~20"	12"~23"

1.5 ENVIRONMENT REQUIREMENT

ambient temperature 0℃~45℃

relative humidity 30~95%

sea level max.1000M

without dust and flammable and explosive gas

The operation space around the machine wills not smaller than the indicated in FIG1

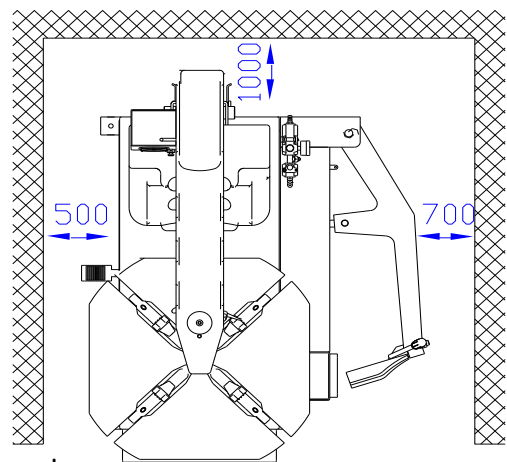

Fig1



It is forbidden to use in the site with the flammable gas !

CHAPTER II CONFIGURATION AND OPERATION

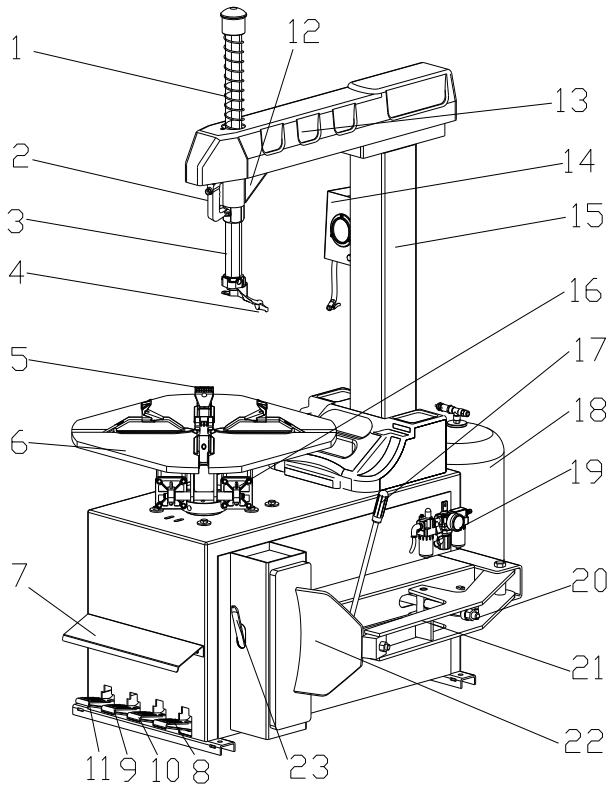

Fig2

1 vertical shaft spring	2 handle valve	3 hexagon shaft	4 demount head
5 claw	6 turntable	7 pedal assembly	8 turntable pedal
9 clamp claw	10 tire press pedal	11 column tilt pedal	12 horizontal pedal
13 lock cylinder	14 pressure gauge	15 column	16 clamp cylinder
17 blade handle	18 air tank	19 air source	20 bead breaking cylinder
21 bead press arm	22 bead breaking blade	23 crowbar	

CHAPTER III INSTALLATION AND CALIBRATION

Before installation and debug, carefully read this manual. The unauthorized change on the parts and spare parts of the machine will cause the damage on the machine.

Installation and debug personnel should have the specific electrical knowledge.

Operators must be trained and authorized.

Before installation, carefully read the equipment list. If any question, please contact with the dealers or our company.

To ensure the success of the installation and debug, please prepare the following common tools:

Two wrenches (10"), one socket wrenches, one hexangular wrench, one tung and one screw driver.

One hammer and one multi-purpose meter

3.1 DEPACKAGE

3.1.1 According to the de-package instruction on the package box, to detach the box and remove the package material

to check if the machine damage or not and if the spare parts completed.

3.1.2 Keep the package material far away from the working site and deal with it properly.

3.2 COLUMN INSTALLATION

3.2.1 According to the requirement of the FIG1, position the body of the machine onsite. Un-package the accessory box and take out the rotation shaft assembly(FIG3-1) and the push-out shaft assembly(FIG3-2) and clean and spread the lubrication oil.



Fig3

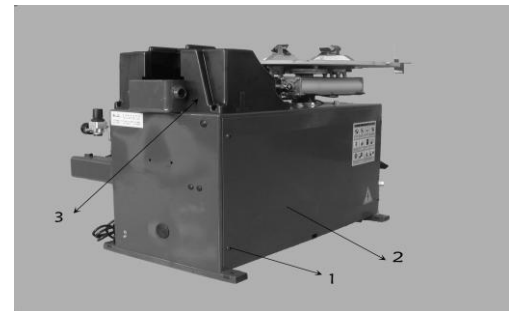

Fig4

3.2.2 Remove the fix screw(fig4-1) and remove the side panel(fig4-2) and the fix screw (fig4-3) on the tool box and take off the tool box.

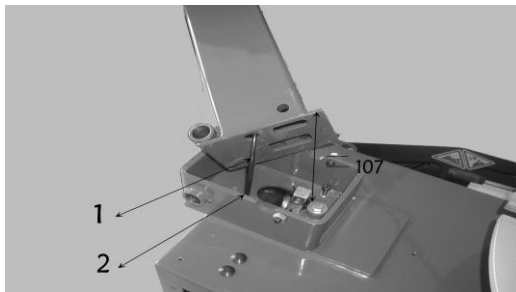

Fig5

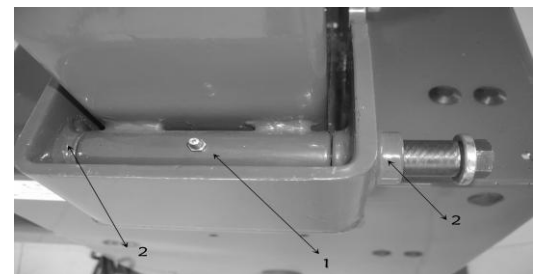

Fig6

3.2.3 Lift up the column and insert the PU hose(fig5-1) at the bottom into the hole (fig 5-2) on the top of the body. Adjust the position of the column to make the rotation shaft bushing (fig6-1) align to the rotation shaft base (fig6-2) on the two sides of the upper base of the body. Remove the nut and the washer at the one end of the rotation shaft assembly (fig3-1) and put the shaft in the hole to make the terminal of the shaft 1mm lower than the level of the base. And then twist on the washer and the nut. The torque is 70N·m.

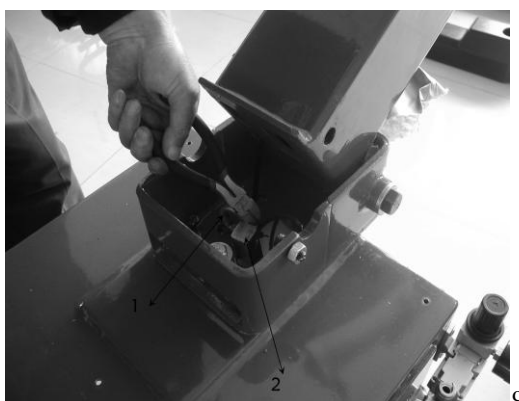

Fig7

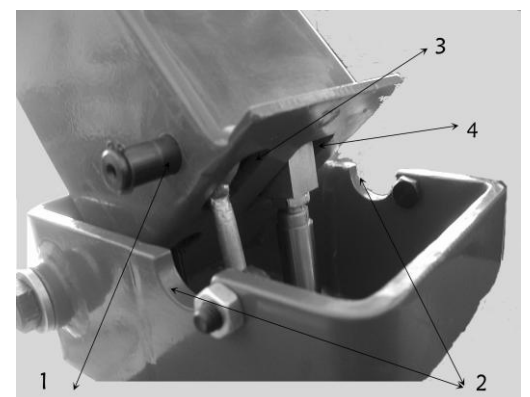

Fig8

3.2.4 Tilt back the column and cut off the tie of the fixed shaft (fig7-1) and the push-out piston rod (fig7-2) .

3.2.5 Position the $\Phi 16$ hole(fig8-1) in front of and below the column at the position of the semi-cycle hole (fig8-2) on the upper seat. Detach the retaining washer on the one side of the push-out shaft (fig3-2) and insert into the corresponding holes of the shaft(fig 8-3) and cylinder piston rod (fig 8-4) though the $\Phi 16$ hole and out of from the hole of the other side and then assemble the elastic retaining washer.

3.2.6 Assemble the PU hose inserted into the body in the step 3.2.3 into the Tee of the air source hose in the body. (fig9)。



Fig9

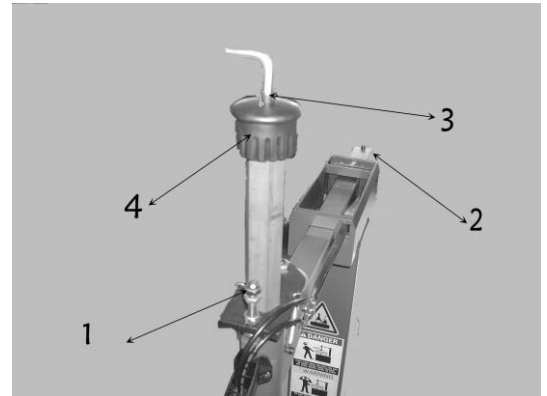

Fig10

3.2.7 Install the horizontal arm protective cover: Remove the cap nut (fig10-1) in the front and the protective fix screw at the back end (fig10-2) and the fix screw (fig10-3) at the upper end of the vertical cap (fig10-4) and remove the vertical cap.



When detaching the vertical shaft cap, please support the vertical shaft well to prevent the vertical shaft from falling off to injury the person.

3.2.8 Remove the package of the protective cover. Twist on the cap nut (fig11-2) and fix screw (fig10-3), Install the vertical shaft spring (fig11-4)、vertical shaft cap and fix screw (fig10-4)、(fig10-3) and fix.

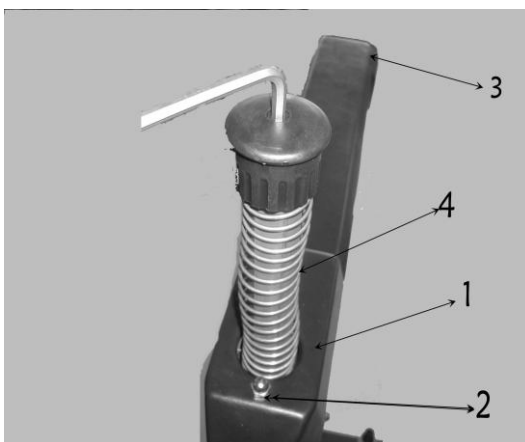

Fig11

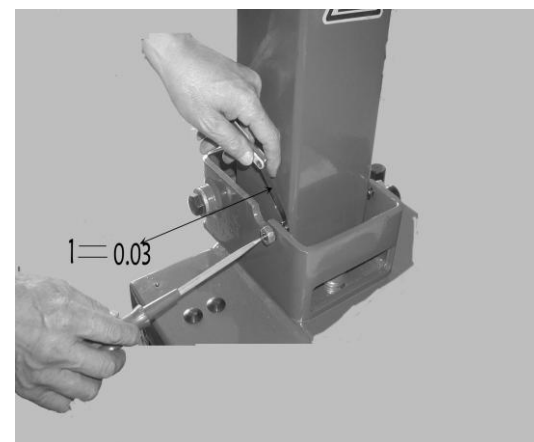

Fig12

3.2.9 Adjust the position screw on the two sides of the column: Loose the nuts on the two sides and adjust the gap between the head of the screw and the side of the column to make it to be 0.03mm (fig12) and then lock the nut.

3.2.10 AIR ROUTE TEST:

Connect the air source, use the lock air valve push button to lock the horizontal arm following the fig 2-2. Step the column tilt pedal (fig2-11) and the column will tilt backwards by about 25°. The velocity of the movement of the column has been set to be about 2seconds one stroke. After long time of operation, the speed will become faster or slower, at this moment, you can use the speed adjusting valve to adjust the speed: Loose the nut, twist the screw clockwise, the speed will decrease and counter-clockwise, increase. After adjustment on the screw, you can tight the nut.

3.2.11 Fix the side panel and tool box removed in the step 3.2.2. Now the installation of the column completed.

3.3 AIR SOURCE FITTING INSTALLATION:

When the machine out of the factory, the air source fitting has been detached and placed in the accessory box and the fitting will be installed when it is in the site of the customers again.

3.3.1 Take out the air source fitting out from the accessory box and the screw and remove the oil and dust. Use the screw to fix it on the right side of the body (fig13).

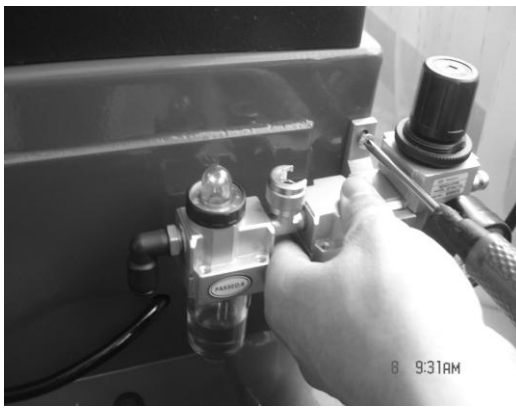

Fig13



Fig14

3.3.2. Connect the air hose, detach the adapter of the ø8 PU hose on the side of the body. This adapter has the function to avoid the hose from sliding into the body. Insert the adapter into the elbow. See the fig14 and fig15.

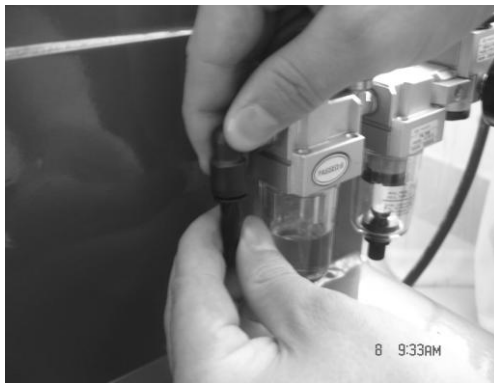

Fig15

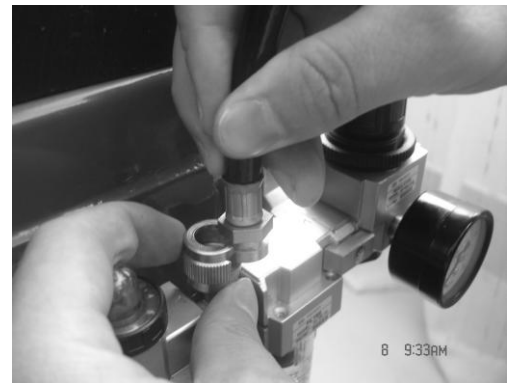

Fig16

3.3.3 Connect the inflation gun and the inflation gauge box : Inlay the adapter of the inflation gun or inflation box into the open nut on the air source fitting. Tighten the open nut. See the fig16 and then connect the air source.

3.3.4 Air source has been adjusted before ex-factory. If it needs change,

adjust again:

Pressure: Lift up the pressure adjustable button(FIG17-1) and twist clockwise

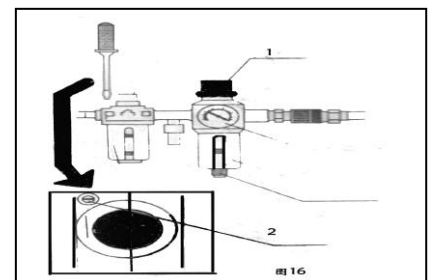

Fig17

and the air pressure will increase. Meanwhile, if counterclockwise, the air pressure will decrease.

Oil Feed: Use screw driver to twist the screw (FIG17-2) . If clockwise, the oil dropping speed will slow. If counterclockwise, it will become fast.

CHAPTER IV DEMOUNT AND MOUNT TIRE

4.1 DEMOUNT TIRE

4.1.1 Deflate the air in the tire completely and pull out the core. Use the special tool to detach the weight on the rim (FIG18).

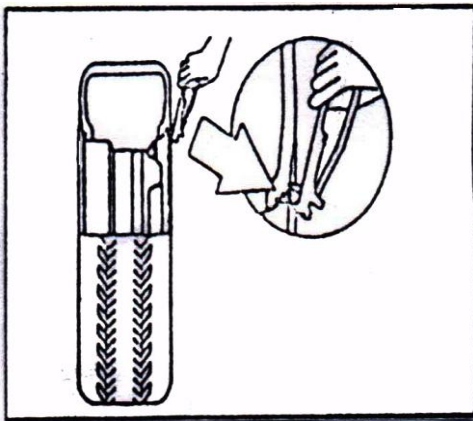

Fig18

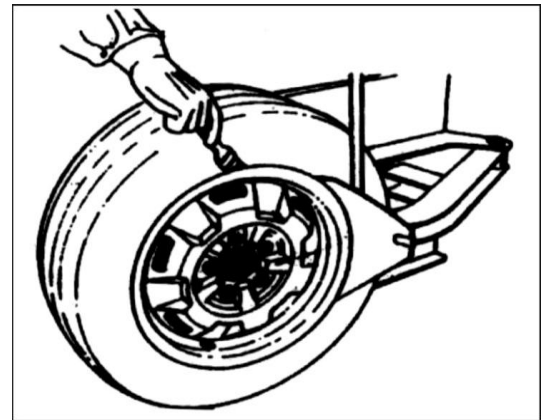

Fig19

4.1.2 Place the tire between then bead breaking blade and tire pressing runner clog. Position the bead breaking blade beside the lateral side of the tire (FIG19).Then step down the pedal to detach the rim from the tire(fig2-10). Repeat the same operation on the other parts of the tire to make the tire completely detached from the rim. To detach the lip smoothly, you can use the brush to spread the lubricant or thick soap liquid between the lip and rim. Place the wheel with the tire detached from the rim on the turntable and step the clamp pedal(fig2-9) to clamp the rim. You can select the outer clamp (fig20) and inner clamp (fig21) to clamp the wheel according to the different rim.

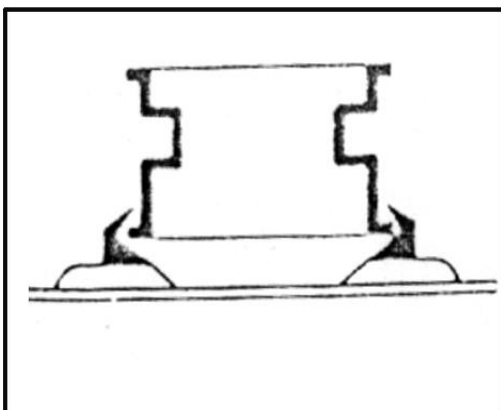

Fig20

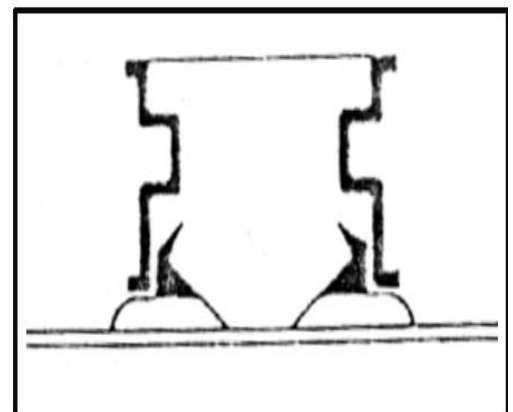

Fig21

4.1.3 Move the hexangular shaft to the working position to make the demount tool close to the rim of the wheel. The cylindrical roller in the demount tool will contact with the external rim of the rim and the bottom of the demount tool will contact with the surface of the rim. Press the lock handle press button (fig2-2) to lock horizontal arm and hexangular shaft and the hexangular shaft will automatically move upwards. The quadric shaft will automatically backward a little to make the demount tool detached from the rim of the rim to avoid the damage on the rim. (fig22) .

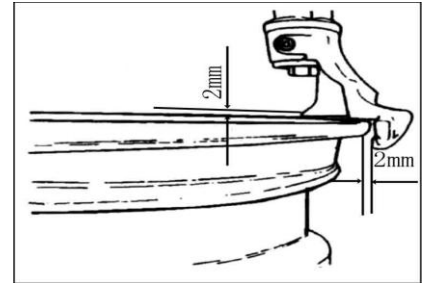

Fig22



The angle of the demount tool has been calibrated according to the standard rim 13" . If handling the extra-big or extra-small rim, you can reposition.

4.1.4 Use the crowbar to detach until the lip to the hump of the demount tool (fig23). Step the turntable rotation pedal (fig 2-8) to rotate the turntable clockwise until the rim of the wheel fall off. If handling the tube tire, to avoid the damage on the tube, you should keep the nozzle of the tire 10cm from the right side of the demount tool See fig24.



If the demount of the tire is jammed, please stop the machine immediately and then lift up the pedal to let the turntable rotate counterclockwise to remove the resistance !

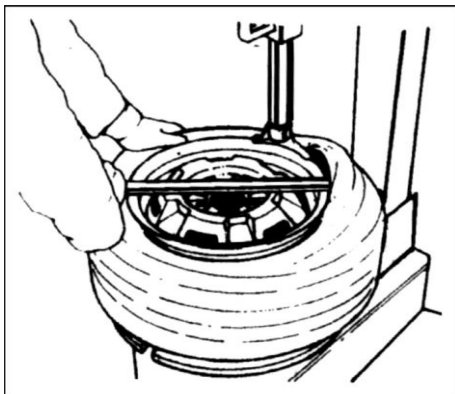

Fig23

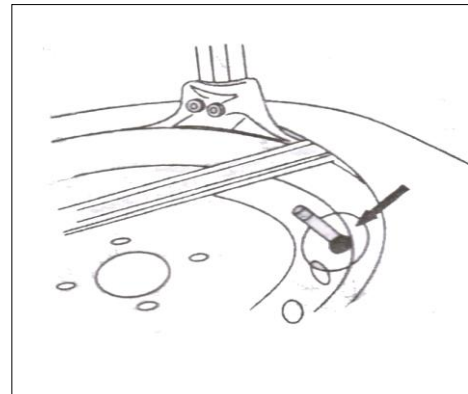

Fig24

4.1.5 Take out the tube and then move up the lower lip to contact with the upper edge of the rim and repeat the step of 4.1.4. Detach another lip (fig25) . Step the column tilt pedal(fig2-11) and the column tilt backwards and at this moment, you can take off the tire.



Necklace, bracelet and loosen clothing is easy to hook and injury the person

4.2 MOUNT TIRE:



Before mounting the tire, check if the rim and tire featured with the same dimension !

4.2.1 Clean up the oil and rust on the rim and lock the rim on the turntable. You can select the inner and outer clamp.
But

the tire detach groove must be in the relative higher position.

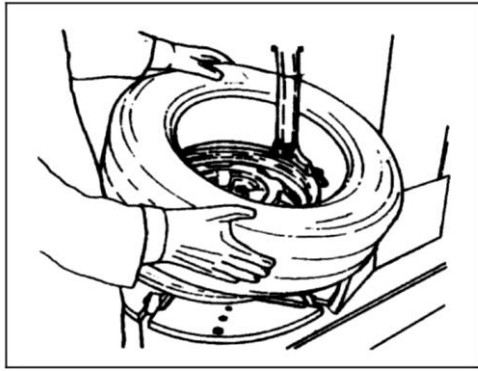

Fig25

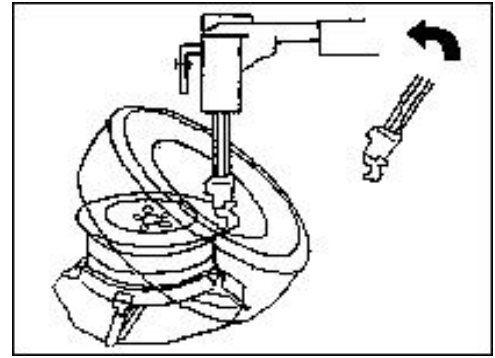

Fig26

4.2.2 Spread the lubrication liquid or soap liquid around the lip. Tilt the tire against the rim and keep the front end upwards. Press down the column tilt pedal (fig2-11) to make the column return to the original position. Move the demount head to firmly contacted rim(fig22). Position the left of the lip above the tail of the demount tool and the right under the hump of the demount tool. See FIG 26.

4.2.3 Press down the right side of the tire as hard as you can and step turntable pedal (FIG2-8) to rotate the turntable clockwise to guide the lip into the tire detach slot completely.

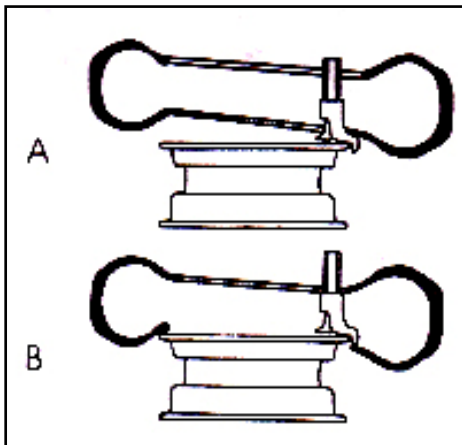

Fig26A/B

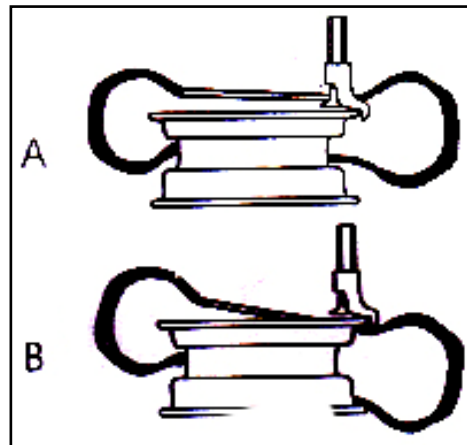

Fig27

4.2.4 If there is tube, raise up the demount tool and put in the tube and position the core.

4.2.5. Mount the demount tool again. Adjust the position of the upper lip. Use the assistant press roller and press to press the side of the tire to make partial of the lip into the tire detaching slot. Step the turntable rotation pedal to rotate the tire. At this moment, continue pressing the lip just mounted on the rim. When 10~15cm of the tire not into the rim, change to the step mode. And observe the condition of the tire to avoid the tear of the tire. Once you feel there is any tear on the tire, release the pedal at once. Then lift up the pedal by instep to make the motor rotate reverse. Make the tire restore to the original condition to mount again.

4.3 Common Inflation:

When inflating the tire, please be carefully and series obey the operation process. Check the air route to see if the air connection is OK. This machine is equipped with an inflation gauge for monitoring the inflation of the tire and the

inflation pressure. (fig 2-14)

1. Loosen the tire from the turntable.
2. Connect the inflation hose with the tire air core. See FIG28.
3. In the process of inflation, you should repeat stepping the inflation pedal. Confirm the pressure indicated on the pressure gauge not exceed the scope specified by the manufacturer. In this machine, there is a pressure decrease valve to keep the inflation pressure not exceed 3.5bar. Customers can get different inflation pressure by adjusting the pressure decrease valve according to their own requirement.
4. If the inflation pressure is too high, you can press down the deflation press button on the inflation device to reach the required air pressure.

4.4 Rapid Inflation(only for the machines with IT)

If the tubeless tire fit to the tire not tight, you can apply the rapid inflation first and then common inflation:

1. Clamp the wheel and connect the inflation hose.
2. Step down the inflation pedal to the bottom position (second gear) and quickly release the pedal when the tire is full to the position of the first gear
3. Repeat stepping the pedal for many times to confirm the pressure indicated on the pressure gauge not exceeds the pressure specified by the manufacturer.

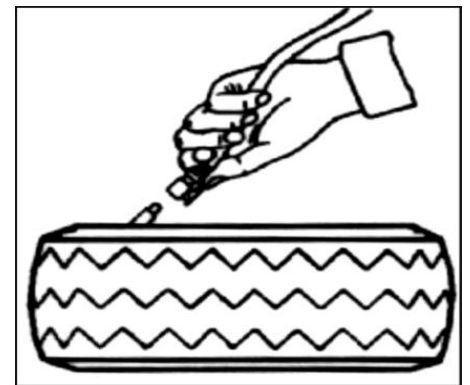

Fig28



Note: In this process, you should ensure the wheel has been tightly clamped. Or you will be in the
us
of lose your life.



Warning! Explosive!



When inflating, please obey the following instructions:

*Carefully check if the tire and the rim are of the same dimension and check the wear condition of the tire to confirm the
the
tire not damaged before inflation.

* When the air pressure needed for inflation relatively high, you can take off the tire and to inflate under the

protective cover.

* When inflating the tire, please be carefully. Keep your hands and body away from the tire.

Chapter V MAINTANENCE & REPAIR

NOTE:

Only the qualified professional personnel can execute the maintenance. Before any maintenance, Cut off the power .

And ensure the maintenance personnel can take charge of the power plug. Meanwhile, cut off the air supply and push

the air supply switch to the off position and completely deflate the residual air in the machine. To correctly use the tire changer and prolong its working life, it is necessary to periodically maintenance and repair according to the instruction manual. Or the running and reliability of the machine will be affected and the personnel near the machine or the operator will be injured.

5.1 The following position should be monthly maintenance:
Keep the machine and working area clean.

Use the diesel oil to clean the hexangular shaft and quadric horizontal arm.(FIG29),

Use the machine oil to lubricate.

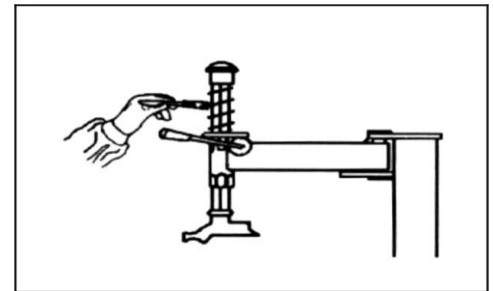

Fig29

Use the diesel oil to clean the turntable claw and its guide and use the lithium base oil to lubricate (FIG30),

Periodically check the lubrication oil level in the oil fog device. If the oil level lower than the oil scale, please feed in the SAE30 lubrication oil in time (FIG 31)

Periodically drain out the water and impurity in the oil water separator.

Periodically check and adjust the tension of the driven belt. Properly adjust the adjust nut in A and B to realize the proper tension. (FIG32) .

Check all the connect parts and tight the loosen bolt.

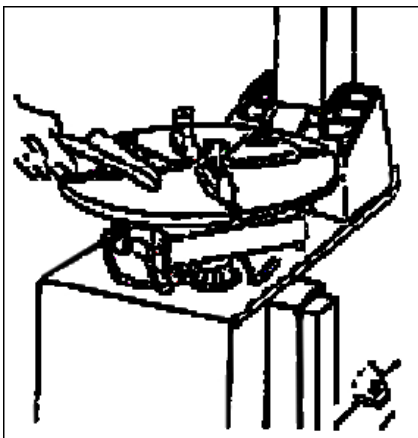

Fig30

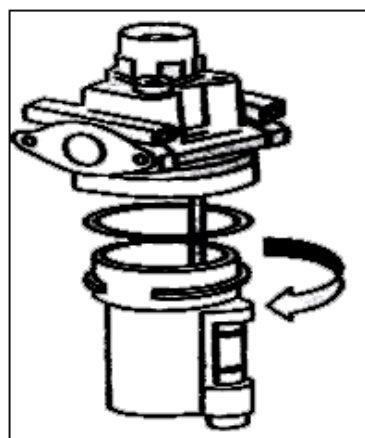

Fig31

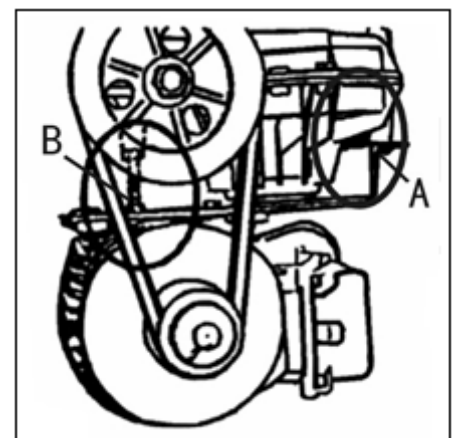

Fig32

5.2 ADJUSTMENT ON THE GAP BETWEEN THE DEMOUNT TOOL AND RIM

5.2.1 VERTICAL GAP: ADJUST THE HEXANGULAR LOCK PLATE:

·Cut off the air supply and remove the vertical hexangular shaft protective cover.

If the gap is too big, you can adjust the upper and lower nut at the front end of the hexangular lock plate downwards. If the gap is too small, you can adjust the upper and lower nut (fig33-1,33-2) at the front end of the hexangular lock plate upwards. Connect the air supply and observe the displacement after lock.

5.2.2 HORIZONTAL GAP: ADJUST THE QUADRIC LOCK PLATE:

Cut off the air supply and remove protective cover at the upper end of the horizontal arm. Use the wrench to loose the lock cap on the M6 screw at the 2 ends. Adjust the M6 screw at two ends (FIG 33-3), meanwhile push the quadric shaft until it moves horizontally smoothly. Then lock the nut. Use the wrench to adjust the screw in the middle (FIG33-4), meanwhile lock the horizontal arm and observe the gap backwards. When the gap is 2mm, lock the nut.

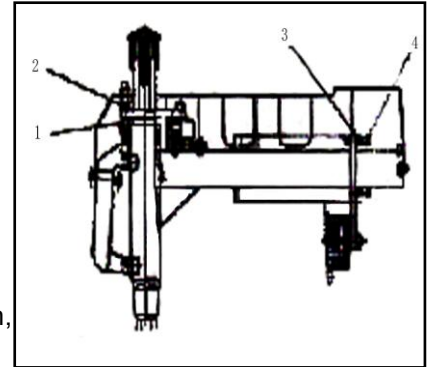

Fig33

CHAPTER VI INSTALLATION & OPERATION OF THE ASSISTANT ARM

PL330 (left assistant) and AL335(right assistant) are the important assisting device of the tire changer. They can independently or combined together on the tire changer dealing with the tires with the diameter of more than 20" to help demount and mount the stiff and flat tire to complete the work that only the operator can hardly complete or impossible to complete.

6.1 INSTALL THE LEFT ASSISTANT



Before installation, the power and air source must be cut off!

6.1.1 The left and right side of the base plate of body of the tire changer which can handle the tire with the diameter of more than 20" all have the installation hole for the left assistant prepared. Before installation, you can remove the side panel and take off the installation rubber plug. If there being the tool box, you should detach the tool box.

6.1.2 Detach the package of the PL330assistant. Check the accessory according to the pack list. After confirmation, takeout the base assembly(fig34) and remove the screw and washer on it.

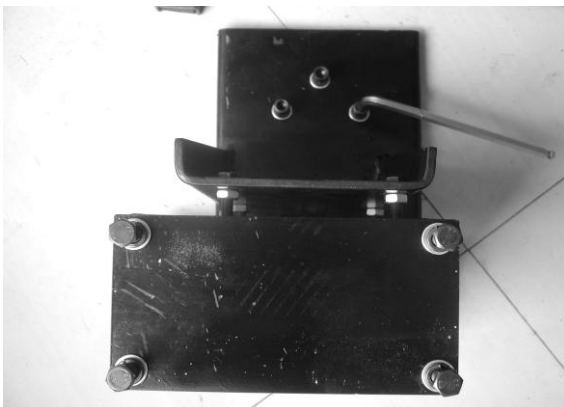

Fig34

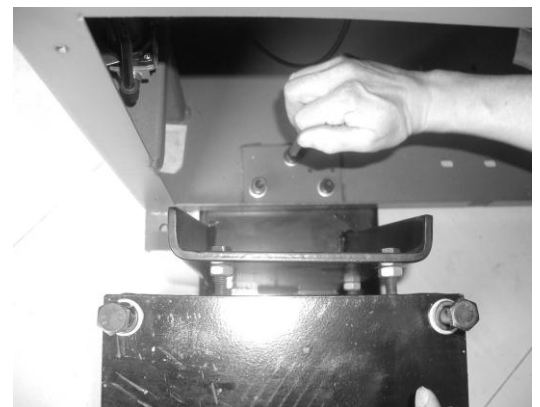

Fig35

6.1.3 Push the platform of the base plate of the base assembly into the body through base plate on the left-back side

of the
body. Align the thread hole to the reinforce hole and use the bolt and washer to fix. (fig35) .

6.1.4 Install the body bracket (fig36-1) on the seat assembly. Align. Use the screw removed before to fix and not tighten

6.1.5 Use the fix supporting bracket (fig37-1) to connect the body bracket and the body and insert the screw to fix.

6.1.6 Connect the air source hose(fig38-2) and use Y Tee to connect the outlet hose and the other end connect with the inlet of the assistant pressure adjusting valve.

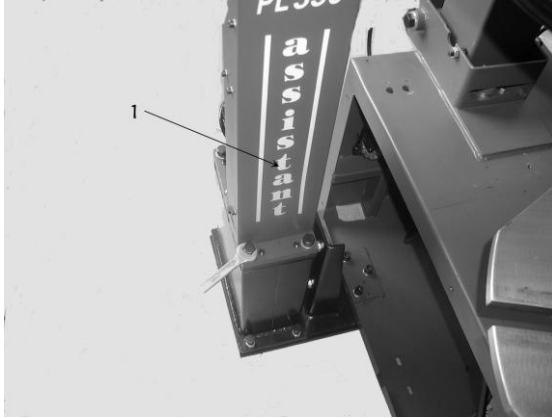

Fig36

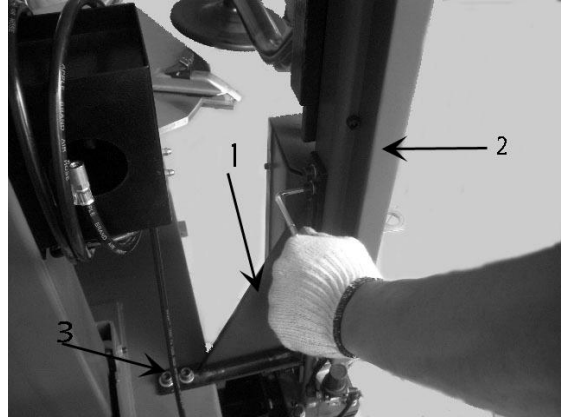

Fig37

6.1.7 Connect the air source, insert the press cone roller connect rod (fig39-1) into the rotation shaft hole(fig 39-2) of the rotation arm. Handle manual direction change valve to make the tip of the press cone roller coincide to the center of the turntable (fig40) . If not coincide, use the screw to adjust the position of the base to realize the coincide. After adjustment, fix the bolt.

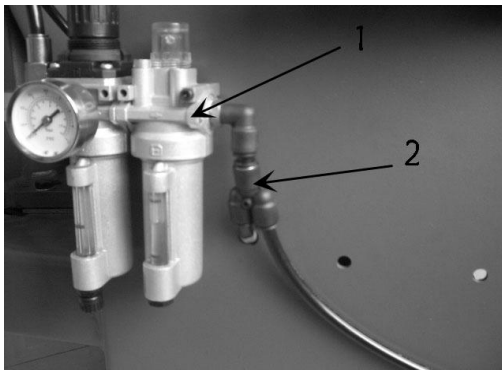

Fig38

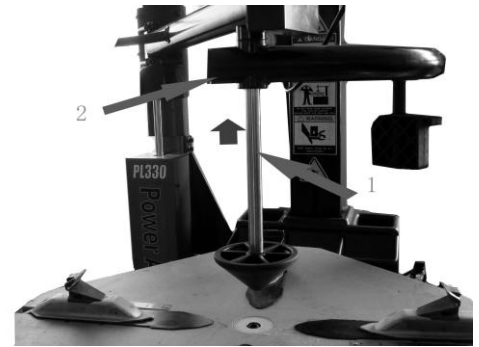

Fig39

6.1.8 According to the fig41, fix the fix bracket on the body and fix the tool box on the fix bracket and then use the lock nut to tight.

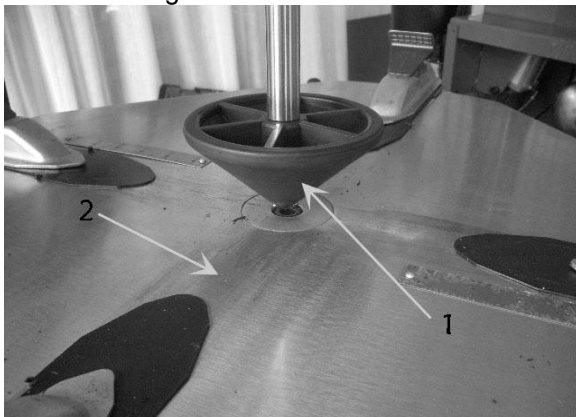

Fig40



Fig41

6.1.9 As fig42, fix the cone support on the body bracket and install the press cone on the bracket.

6.1.10 Loosen the nut below the base and turn the screw clockwise until it against the ground and tight (fig43) and install

The side panel and tool box removed in the 6.1.1. At this moment, the installation of the left assistant completed.

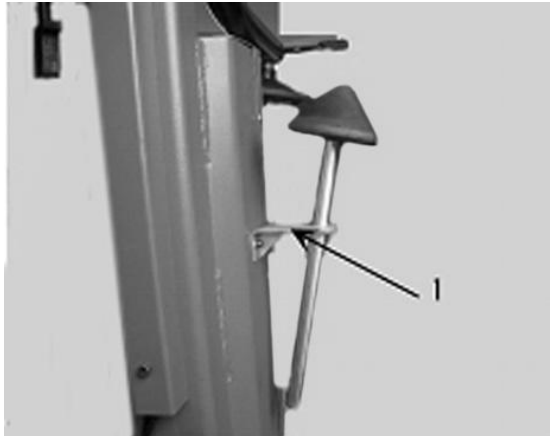

Fig42

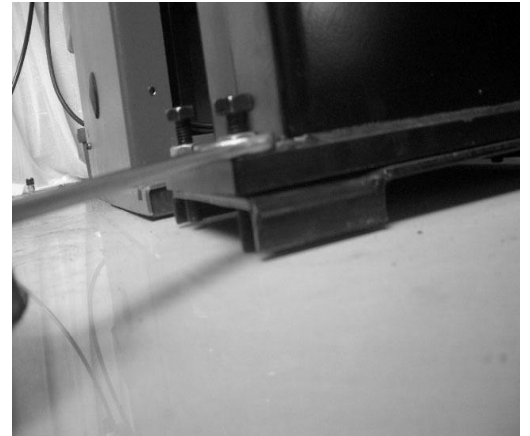

Fig43

6.2 INSTALL THE RIGHT ASSISTANT

6.2.1 After detach the tire from the rim according to the instruction of the chapter IV, we can execute the following operations.

6.2.2 First, position the claw according to the dimension of the tire and then clamp the rim by the claw and position the tire

press cone roller at the center of the rim(fig44) . Push down the manual valve to press down the rim until the external rim of the rim is lower than the surface of the claw. At this moment, you can immediately lock the rim. Lift up the support arm

and place it at the working position and take off the press cone roller and place it on the support. (fig42-1).



Fig44

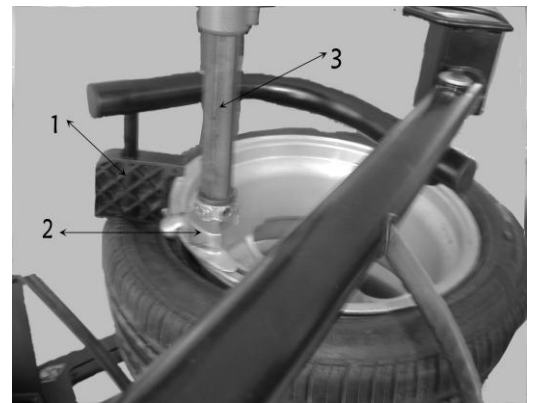

Fig45

6.2.3 Use the press(fig45-1) to press down the tire section by section rim detached from the mouth and use the brush to

spread the lubricant on edge of the lip. Position the demount tool(fig45-2) in the demount position. Place the press

beside of the demount tool to press down the lip and insert the crowbar below the demount tool in between the rim and lip (fig46),

Lift up the press and move it to the position opposite to the demount tool and press the lip into the tire detach groove and

then rotate the crowbar to lift the lip onto the demount tool (fig47) . Rotate the turntable to detach the upper lip.

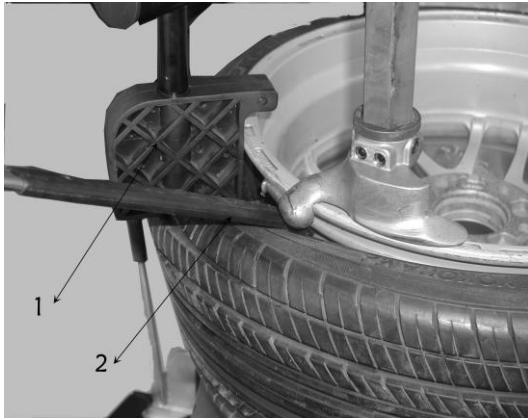

Fig46



Fig47

6.2.4 DETACH THE LOWER LIP: Use the disk to lift up the bottom of the tire from the bottom of the mouth (fig48) and detach the lower lip (fig49) according to the step (4.1.5) .



Fig48



Fig49

6.2.5 MOUNT TIRE

First, according to the step (4.2.1) ~ (4.2.3) , install the lower lip and use the press to press the lower lip as shown in the fig50. Rotate the turntable by about 90°. And then clamp the press in the demount tool (fig51) and continually rotate the turntable until the completion of the operation.



Fig50



Fig51

6.3 INSTALLATION OF THE RIGHT ASSISTANT



You must cut off the power source and air source !

6.3.1 Depackage the package carton and check according to the accessory list and the figure 52. Clean up for assembly. The assembly appearance is as shown in the fig53. And prepare the required tool.

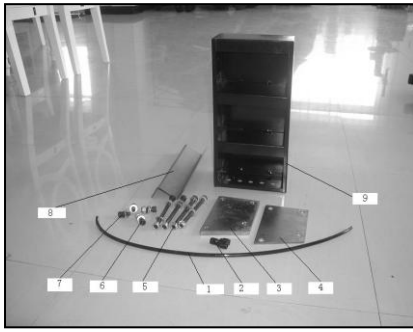

Fig52



Fig53

ACCESSORY LIST: ①ø8PU hose ②ø8 Y-Tee ③plate ④cushion ⑤screw M10X130 (nut、flat washer) 4sets
⑥screw M10X25 (nut、flat washer) 2sets ⑦screw M10X20(flat washer) 2sets⑧fix plate ⑨tool box



Fig54

6.3.2First, place the cushion (fig52-4) on the indicated position on the U-steel (fig54) to make the 4holes of the cushion aligned.

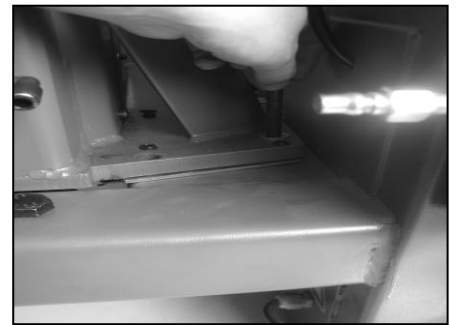

Fig55

6.3.3Upright the body of the assistant on the cushion and use the screw(fig52-5) to fix Insert the corresponding screw (fig56) , assemble the flat washer and use the nut to tight (fig57) .

6.3.4Remove the hose from the end of the air source fitting and use a small section of the ø8PU hose to connect the Y Tee with the outlet and another connected with the air source hose (fig58)



Fig56



Fig57

6.3.5Insert one end of the ø8 PU hose (fig 52-1) into the idle adapter of the Y Tee and another end connected with the inlet of the pressure adjust valve of the assistant.

6.3.6 Use part (fig 52-7) to fix the part (fig52-8) on the corresponding position on the assistant column and tighten. Use part (fig52-6) to fix the part (fig52-9) together with the part (fig52-8) and tighten (fig59) .



Fig58



Fig59

6.3.7 Adjust the vertical of the assistant column: According to the situation, you can loose the screw (fig52-5) to adjust the tight screw on the base plate of the assistant to make the position of the column reach vertical (fig60) . If the column tilt outwards, you should clockwise twist the 2 adjusting screws outside to make the column in the vertical position and if the column tilt inwards, you should clockwise twist the 2 adjusting screws inside to make the column in the vertical position.

After adjustment, you should tighten another 4 fix screws.



Fig60



Fig61

6.3.8 Connect the air source and push upwards the control valve handle and the assistant movable base will slide upwards.

If the handle downwards, the base will downwards. If not exist the phenomenon of air leakage, crawl and climb and normal slide of each part, the installation of the right assistant completed.

6.4 RIGHT ASSISTANT OPERATION

6.4.1 Prepare according to the normal demount method and clamp the tire on the turntable.

6.4.2 Gradually use the cylindrical press roller to press down the tire and meanwhile rotate the turntable and use the brush

6.4.3 to spread the thick soap liquid or the lubricant on between the tire and the rim. (fig61)。

Position the column in the working position and fix the demount tool in the required position to demount tire. (fig62).



Fig62



Fig63

6.4.4 Insert the crowbar into between the tire and rim (fig 62) and use the handle valve to lift up the press roller and return Back. Turn over the crowbar to position the lip above the demount head (fig63) . Rotate the turntable clockwise until the entire upper lip detached.

6.4.5 Make the demount head as the support point and insert the crowbar into the lower lip. Use the circular disk to lift up the bottom of the tire to make it move up until it to the upper edge of the rim (fig 64) and then lower down the disk until ti moves to the un-working position.



Fig64



Fig65

6.4.6 Turn over the crowbar to let the down lip rotate upwards until on the demount head (fig65) . Rotate the turntable clockwise until the tire is completely taken out of the rim.

6.4.7 MOUNT TIRE:

Before mounting the tire, you must clean up then oil and dust and spread the lubricant on the upper and lower lip.

First assemble the lower lip (fig 66) .

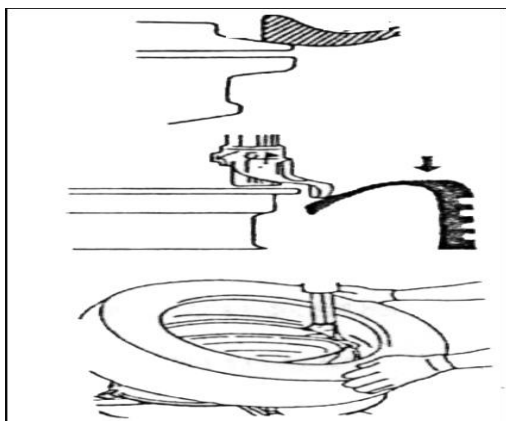

Fig66



Fig67

6.4.8 Place the upper lip on the tail of the demount head and then press cylindrical press roller on the tire to make the upper lip lower than the head of the demount head. Clockwise rotate the turntable. After rotate by 90°, you need add the tire press assist device (fig68) . If apply the dual assistant, you can use the left assistant to press the lip to the tire detach groove (fig68) & keep on rotating the turntable until the tire is completely mounted.



Fig68

CHAPTER VII TRANSPORTATION

When transport the machine must apply the original package and place according to the mark on the package. The machine must be transported by the forklift with the corresponding tonnage (FIG69) and the stacked layer will not exceed 3 layers.

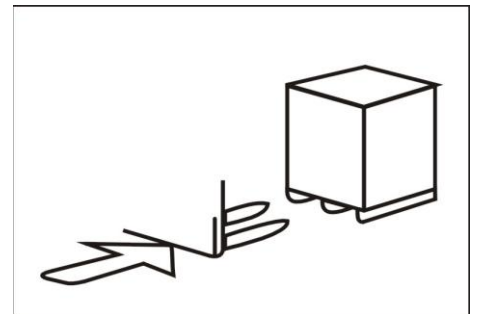
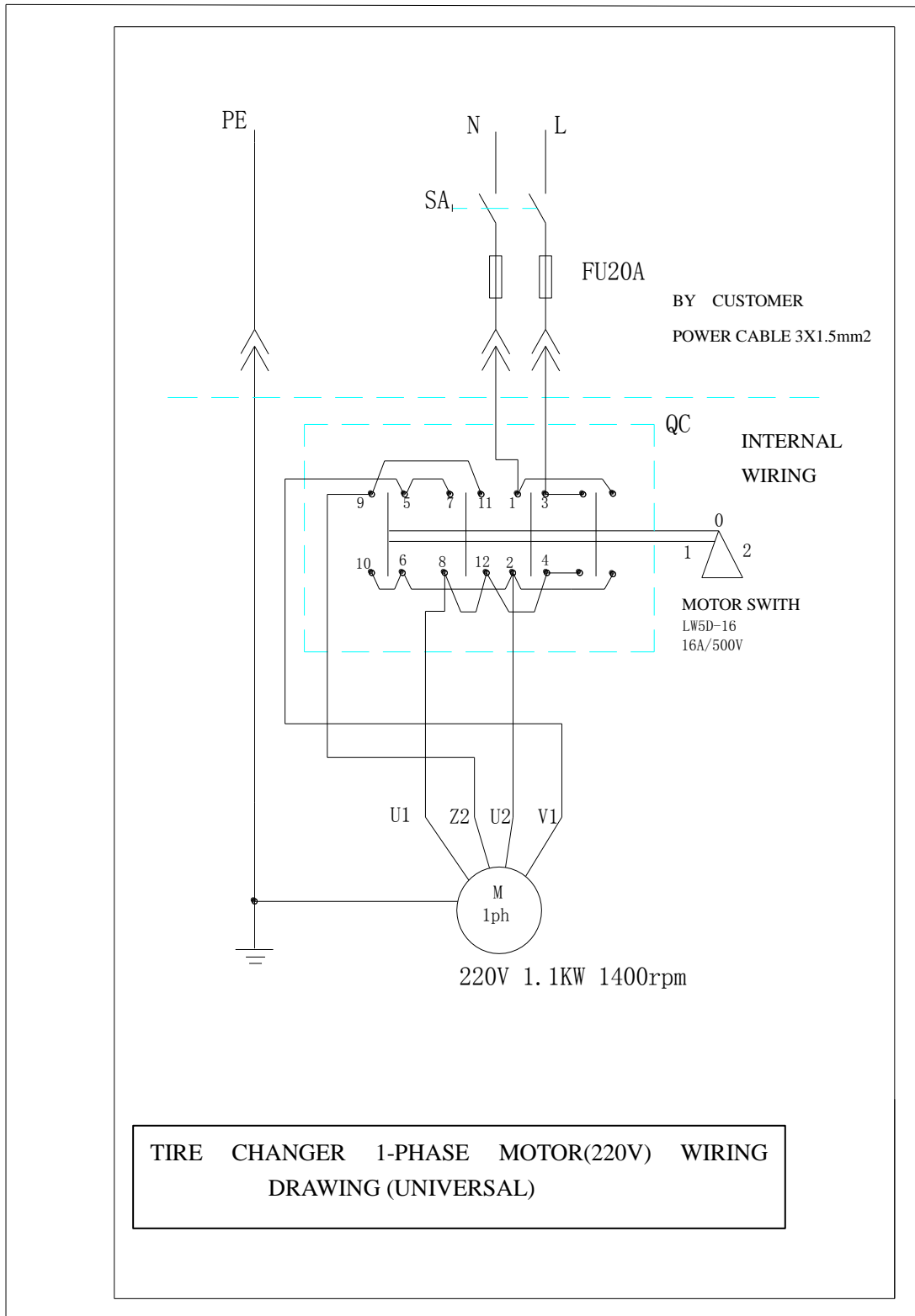

Fig69

CHAPTER VIII ELECTRICAL AND PNEUMATIC DRAWING

- 8.1.220V ELECTRICAL PRINCIPLE DRAWING
- 8.2.380V ELECTRICAL PRINCIPLE DRAWING
- 8.3.110V/220V ELECTRICAL PRINCIPLE DRAWING
- 8.4. PNEUMATIC PRINCIPLE DRAWING

8.1. 220V ELECTRICAL PRINCIPLE DRAWING



8.2. 380V ELECTRICAL PRINCIPLE DRAWING

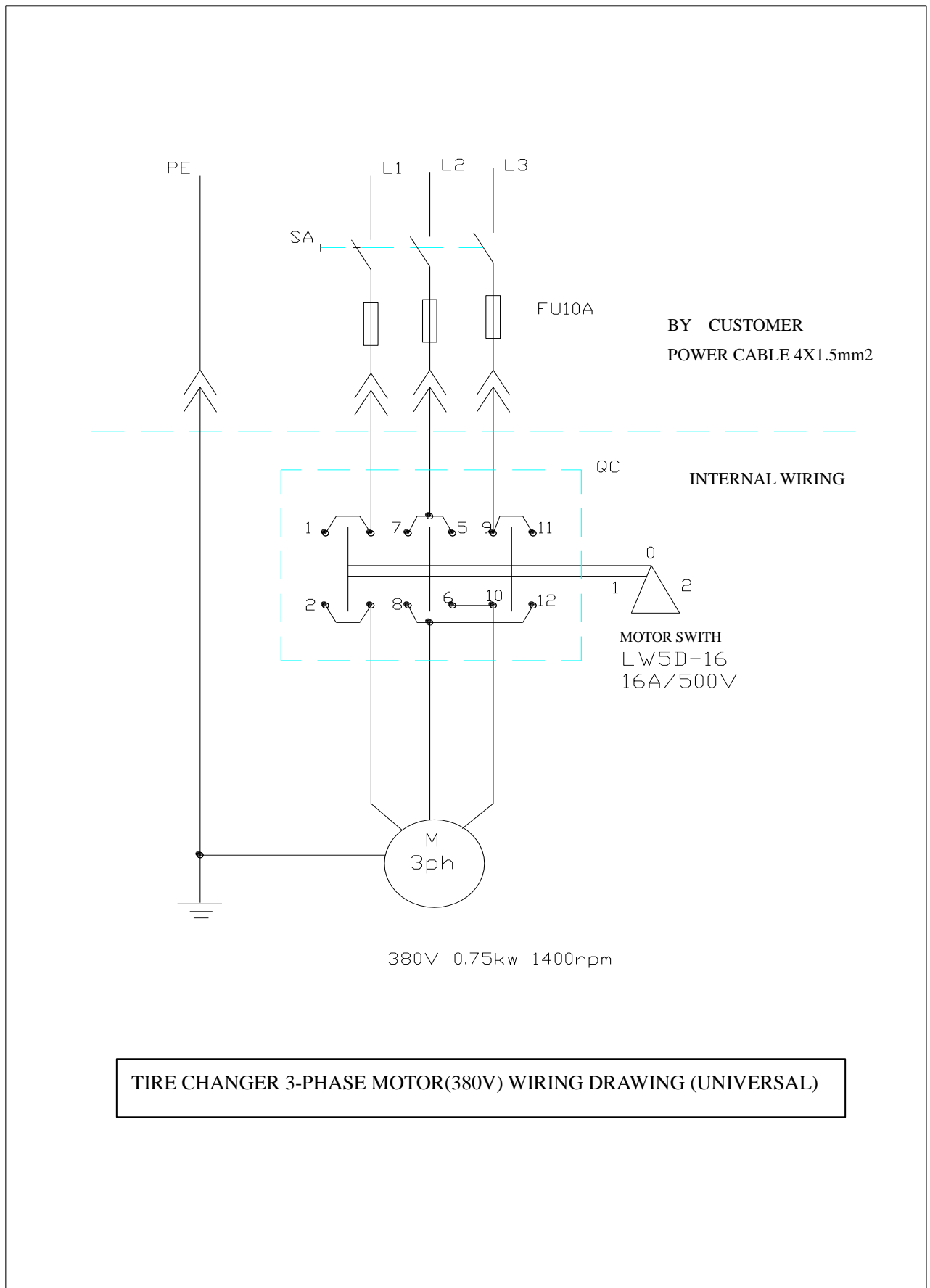

8.3.110V/220V ELECTRICAL PRINCIPLE DRAWING

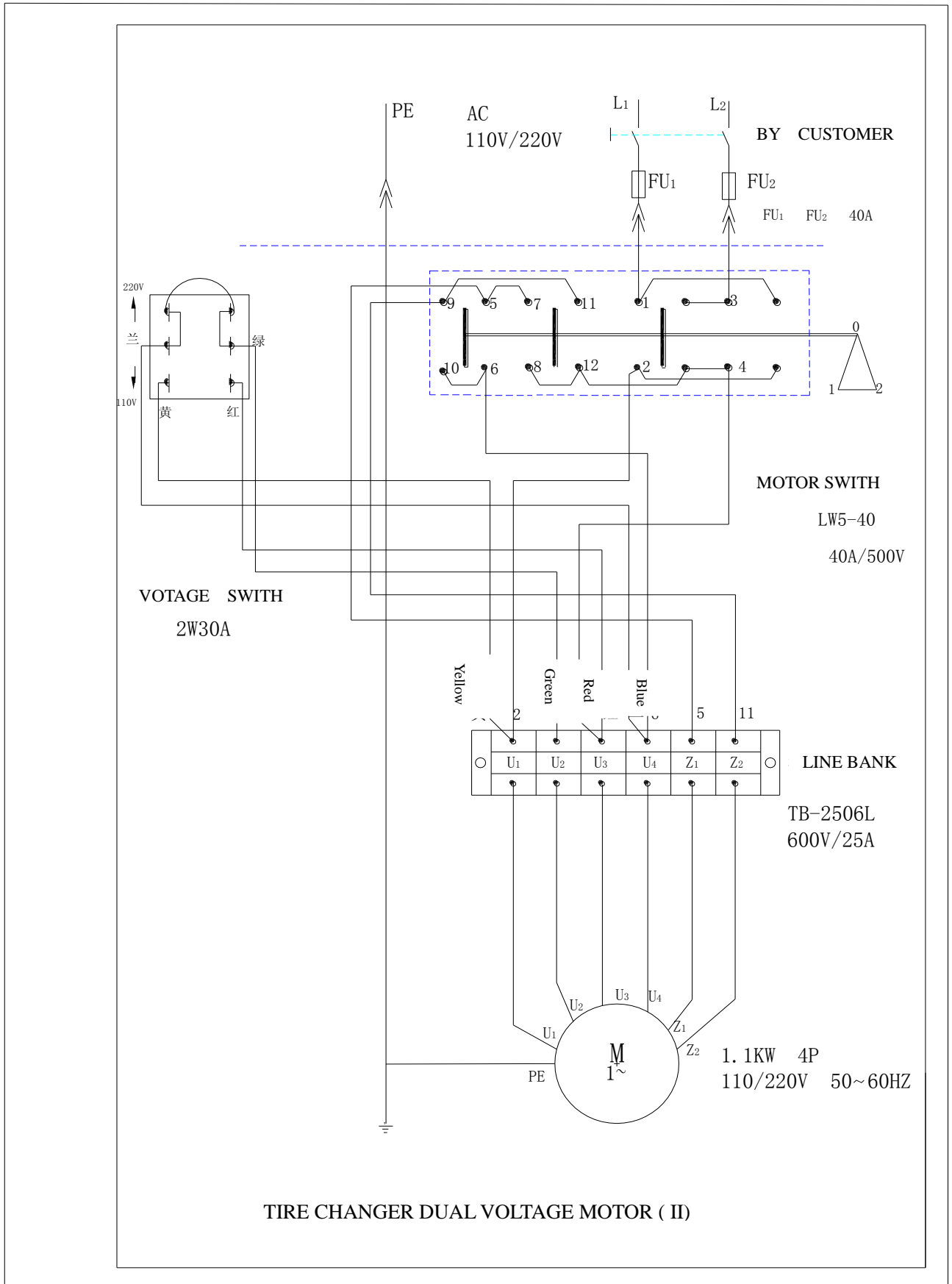

8.4. 103826A PNEUMATIC PRINCIPLE DRAWING

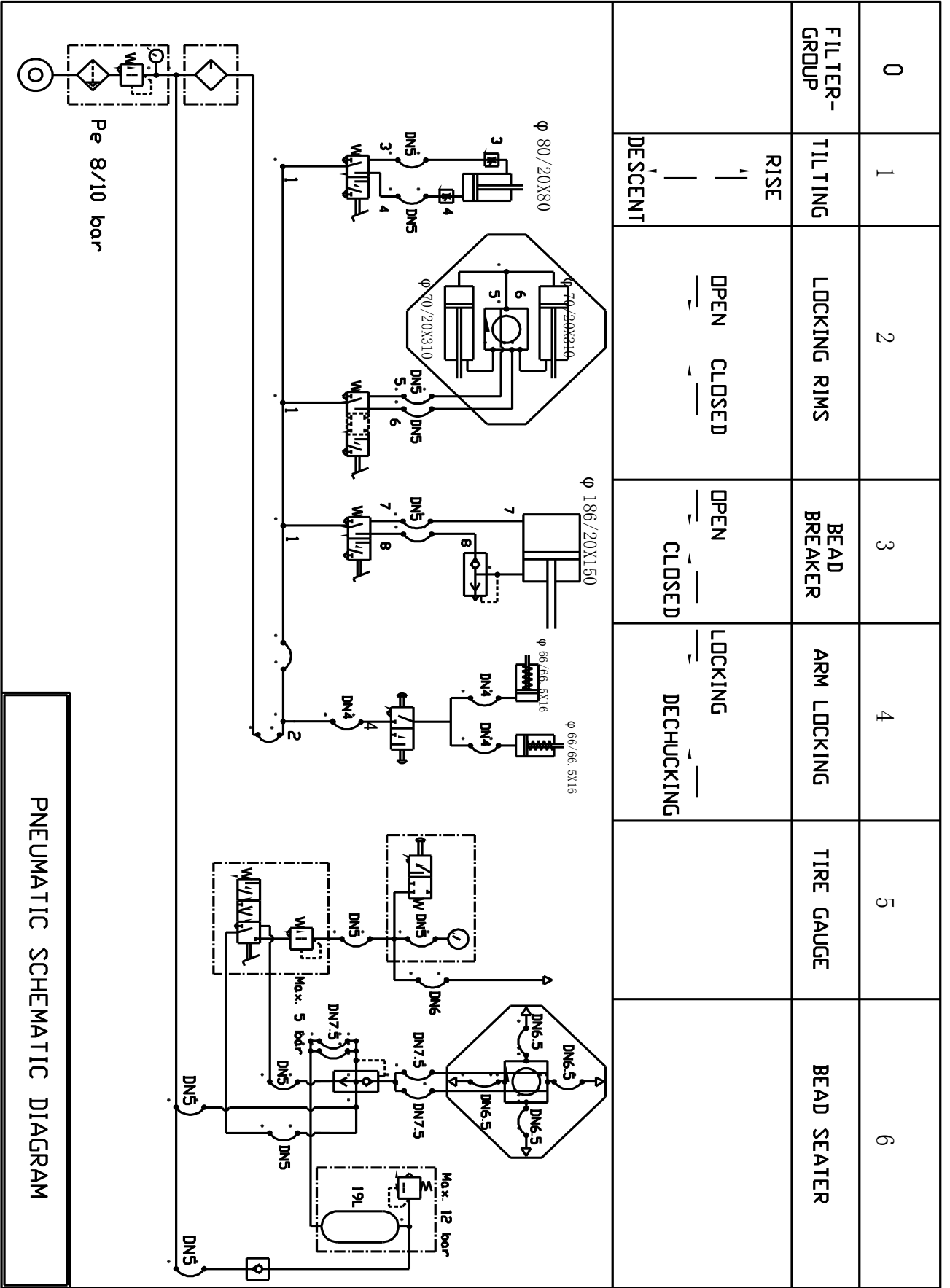

CHAPTER VIII TROUBLESHOOTING ANALYZE AND SOLUTION

TROUBLESHOOTING	REASON	SOLUTION
Turntable rotate in one direction.	Universal switch contact burned	Change Universal switch
Turntable does not rotate.	Belt damage Belt too loose Motor or power source have problems Universal switch contact damage	Change belt Adjust the tension of the belt Check motor, power source and power source cable Change motor if motor burned Change Universal switch
Turntable can not clamp the rim as normal	Claw worn Clamp cylinder air leakage	Change claws Change the air leakage sealing parts
Quadric and hexangular shaft cannot lock	Lock plate not in position Lock cylinder air leakage	Adjust the adjust screw of the lock plate Change the cylinder sealing washer
The horizontal arm fault The vertical movement of the hexangular jamming	The lock position of the quadric lock position not correct The lock position of the hexangular lock position not correct	See Chapter V Adjust the quadric/hexangular lock plate
Column tilt backwards or the return too fast or slow	The deflate of the column cylinder too fast/slow and the air source pressure too slow	Open the side panel and adjust the throttle (3.2.1)
Chassis pedal not return.	Pedal return spring damage	Change torsion spring
Motor not rotate or the output torque not enough	Drive system jam Capacitor broken down Voltage not enough Short-circuit	Remove the jam Change capacitor Wait for the restore of the voltage Remove
Cylinder output force not enough	Air leakage Mechanic fault Air pressure not enough	Change sealing parts Remove the fault Adjust the air pressure to meet the requirement

LC SERIES MACHINE OIL SAFETY DATA SHEET

MOBIL XHP 222

ITEM	QUALITY STANDARD
Penetration rate ^{25°C} mm/10	280
dropping point °C	280
anticorrosion	passed
Basic oil viscosity	220
oxidize stability 100h pressure-drop kpa	35
water lose percentage ^{79%}	5
copper corrosion	1A

SAE30# LUBRICATION OIL

ITEM	QUALITY STANDARD
density 15°C	0.893
Flash point	224
Pour point °C	-18
viscosity 40°C	100
viscosity 100°C	11.2
Viscosity index	97

2# LITHIUM BASE GREASE

ITEM	QUALITY STANDARD
Penetration rate mm/10	278
dropping point °C	187
copper corrosion 100°C 24 h	No change
oxidize stability (99°C 100 h)	0.2
anticorrosion (52°C 48 h)	1 level
similarity viscosity (-15°C、 $10S^{-1}$) / (PaS)	800
water lose(35°C 1h) %	8

CKC460 INDUSTRIAL GEAR OIL

ITEM	QUALITY STANDARD
Viscosity 40°C	461
Viscosity index	92
Flash point °C	212
Freezing point °C	-26
copper corrosion ^{100°C} 3 h	1A
mechanical impurity	0.007
Pour point	-10