



AutoMount 103826

Semi Automatic Tilt Back Tyre Changer

High Quality European Designed

Specification

- External rim clamping: 10" - 20" (254-508mm)
- Internal rim clamping: 12" - 23" (305-584mm)
- Maximum tyre diameter: 41" (1040mm)
- Bead breaker tyre width capacity:
3" - 15" (76-381mm)
- Power supply: 240V / 50Hz/ 1Phase (10 Amp)
- Air supply: 8-10Bar
- Motor power: 0.75KW-1.1KW
- Noise level: <75dB
- Packing Size: 900mm x 1100mm x 1000mm
- Net Weight: 270 Kg

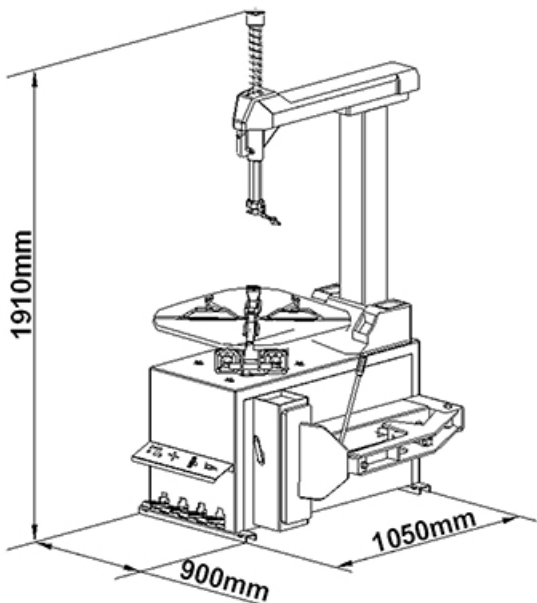

Quality Engineered Gearbox



Bead Cylinder



Tool Head



Single Speed Reversing Switch



Optional motorcycle adaptors available



Inflation Gauge

Features

- Improved design and technology
- Large bead breaking cylinder
- Tilting column and pneumatic locking system
- Chromium alloy demount tool
- Inflation Gauge
- Single speed reversing switch
- Adjustable bead breaker blade